

— CAT



The Duality of the Design

Whether you're chasing endless elevation or sculpting lines on tight, technical singletrack, the Trailcat is your ultimate ride companion, tuned to take every hit, twist and climb. The Trailcat SL and LT share a heritage of high-performance handling and unmatched versatility but cater to two different sides of the same coin. The SL is the tool for those who crave swift, snappy efficiency, while the LT brings longer-travel confidence for those who seek bigger thrills and steeper trails. Whichever you choose, the Trailcat is engineered to be the ideal fit for your style of adventure, helping you go further, faster and bolder.

The Back Story

We designed the new Trailcat SL and LT in the spirit of some of our favorite Pivot models to give us something more. Something that we didn't have but knew we needed. From the moment we launched the lightweight 27.5" Shadowcat, we (as well as our customers) felt that a 29" version of the Shadowcat would be awesome. That sounded great but we had the Switchblade. But then the Switchblade became more capable, and a bit more enduro focused, leaving a golden opportunity for something new and exciting.

Simultaneously, we also had the development of the Shuttle SL going on and it proved to hit a magical sweet spot. Anyone who gets on a Shuttle SL loves that bike (and it's not just because it has a motor). Even turned off there is something special about the way the Shuttle SL handles and feels – We knew we were onto something.

The Back Story

Fast forward to today when the time has come to update the venerable Trail 429 and Trail 429 Enduro models. Certainly, both are a hard act to follow, but in typical Pivot Cycles fashion, we knew we could do better and the Trailcat SL and Trailcat LT were born.

Two new models with an incredible pedigree, bringing the next level of Trail bike performance to the category.

Table Of Contents

07	Trailcat SL
11	Trailcat LT
16	One Frame, Two Bikes
18	Toolshed™ In-Frame Storage
21	Pivot Dock Tool System
23	New Cable Port Design
26	dw-link
28	Flip Chip Adjustability
30	Proprietary Ride Tuning
32	Colors
36	Modern Trail Geometry
39	Geometry
42	Versatile Dialed-In Build Options
44	Spec SL
54	Spec LT
65	Pivot Premier Lifetime Warranty

120-SSL

120mm of Rear Travel

140mm of Front Travel

Trailcat SL

LIMITS REDEFINED

Super light, razor-sharp and unapologetically fast, the all-new Trailcat SL earns its title as the ultimate trail companion by amplifying every aspect of your ride. Its lightweight frame and finely tuned dw-link suspension platform make climbing effortless, delivering smooth, efficient power that turns technical ascents into opportunities rather than obstacles. Agile enough to navigate tight switchbacks and composed enough to handle rough, fast descents, the Trailcat SL is as versatile as it is fun. From spirited after-work loops to all-day adventures, it combines efficiency, precision and stability in a way that inspires confidence on any terrain. This is a bike that amplifies every ride, delivering the kind of experience that makes your heart race and your face light up. Whether tackling new trails or returning to your favorites, the Trailcat SL proves time and again why it's the ultimate trail companion.





135MM

150MM



135mm of Rear Travel

150mm of Front Travel

Trailcat LT

ROWDY & REFINED

The all-new Trailcat LT isn't a bike that fits neatly into the typical trail category—it's a ride for those who crave more. When 120mm of travel just isn't enough but you don't want to give up that magical pedaling performance of a short travel trail bike, then the Trailcat LT is your answer! It combines the nimbleness of a short-travel trail bike with the aggressive spirit of a bike that craves everything from flowy singletrack to steep, technical descents. When the trail turns rowdy, the LT punches above its weight class and thrives in the excitement. If you seek efficiency on climbs but want the confidence to charge hard on descents, the Trailcat LT is built for you. No compromises. Just pure, unfiltered, category defying fun.

13





15



One Frame, Two Bikes

Both Trailcat SL and LT models utilize the same front and rear triangle as well as the same lower dw-link.

Geometry and kinematic differences between the SL and LT are achieved through distinct upper links, a flipable lower shock tab mount and different shock lengths, fine-tuning the ride characteristics for each model.



Toolshed™ In-Frame Storage

The new Pivot Toolshed™ in-frame storage system keeps your essentials securely tucked away, reducing clutter and providing quick, easy access for all your trail adventures, from short rides to longer excursions. Designed to be completely rattle-free, it ensures your gear stays silent and secure, even on the roughest terrain.

The Toolshed™ door is a work of engineering art with the easiest to use and most secure latching system on the market. An integrated magnet on the inside of the door holds quick links for fast and easy access. Strap your favorite tool or accessory to the inside of the door using the integrated strap loop (strap not included).

Each Trailcat includes two Toolshed™ bags, designed to carry a spare inner tube, essential tools and even a bit of extra space for a snack.



Toolshed In-Frame Storage

Table Of Contents



Pivot Dock Tool System

Pivot's exclusive on-the-bike tool system created in collaboration with Topeak

Unweight hydration packs by strategically locating essential repair items under either the top tube or BB

Available as Dock Ninja C02, Dock Ninja Tool Box T16+, Dock Ninja Trifecta or Dock Ninja Tool Box Mini 20 Pro



New Cable Port Design

The dual cable port allows for two hoses to be routed through the same port, simplifying cable routing at the head tube both visually and practically.

The larger opening provides an easier and more efficient routing process for your cables.

New integrated cable clips inside the Toolshed™ keep cables and housing secure, silent and hidden.



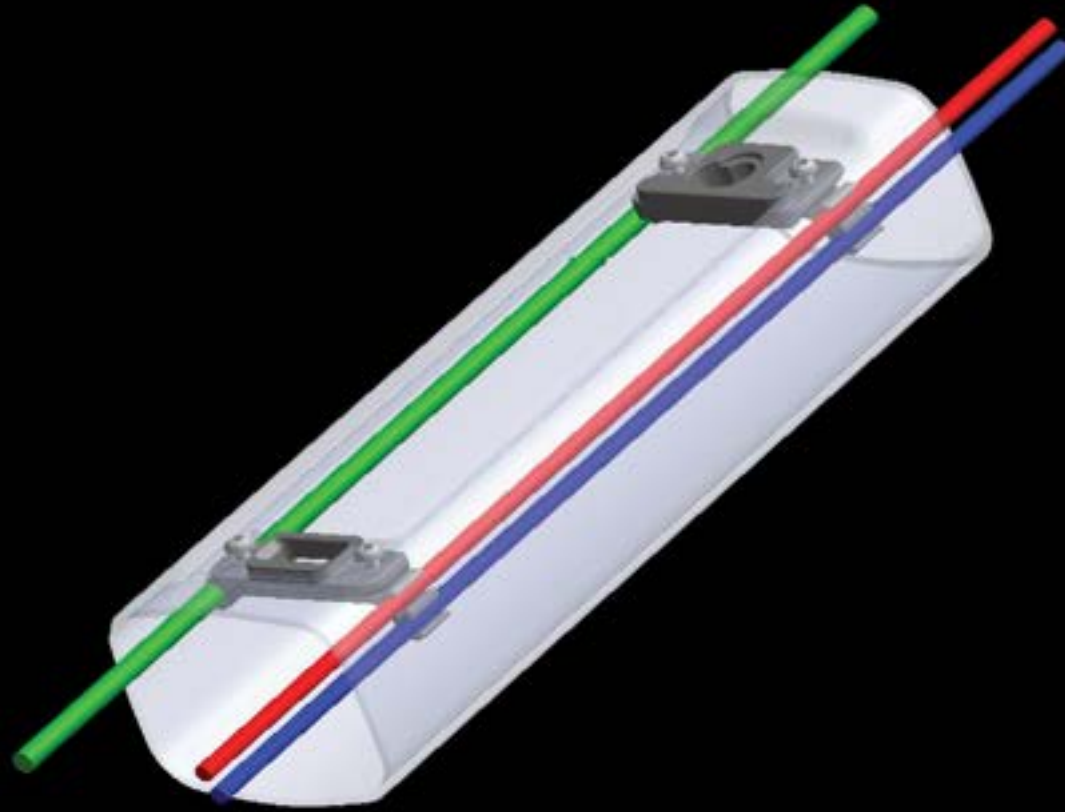

dw-link

The dw-link suspension design maximizes traction and pedal efficiency on every climb, all while maintaining a plush, bottomless feel when charging through chunky descents.

dw-link suspension enables the Trailcat SL to pedal like an XC bike and descend better than any 120mm bike has a right to while the Trailcat LT pedals like a short travel trailbike and descends with the capability of an enduro race bike.

dw-link

Table Of Contents



Flip Chip Adjustability

“Low” and “High” settings on the Pivot Flip Chip allow riders to easily configure geometry or adjust for different wheel sizes.

The high BB setting will raise the bottom bracket and steepen the head angle by 0.5 degree or allow for the use of a 27.5” rear wheel making all sizes of both the Trailcat SL and Trailcat LT mixed wheel compatible.



Proprietary Ride Tuning

Fits riders 4'11" to 6'5"+ with size range X-Small through X-Large

Independent strength to weight analysis for each frame achieves consistent performance metrics

Custom-tuned carbon scales stiffness across all sizes, ensuring optimal ride characteristics for all rider profiles

For more information regarding Pivot's Proprietary Ride Tuning check out the journal: [LINK TO JOURNAL](#)



Colors

32

SL



LT



Table Of Contents

Dr Purple



Green Meadow Mist





Modern Trail Geometry

Unique upper links and lower shock mount locations allow the Trailcat SL and Trailcat LT to maintain proper geometry tailored to each model's performance





SIZES (LOW)	XS	SM	MD	LG	XL
A Seat Tube Length (C-T)	34.3	36.8	39.4	43.2	47.0
B Top Tube Length (Eff.)	56.9	59.6	62.9	64.9	66.0
C Head Tube Length	8.5	9.5	10.7	11.2	12.5
D Head Tube Angle	65.8°	65.8°	65.8°	65.8°	65.8°
*E Seat Tube Angle (Eff.)	76.0°	76.0°	76.0°	76.0°	76.5°
F Chain Stay Length	43.1	43.1	43.1	43.2	43.4
G Bottom Bracket Height	33.8	33.8	33.8	33.8	33.8
H Bottom Bracket Drop	3.6	3.6	3.6	3.6	3.6
I Standover Height	65.3	67.4	67.8	69.2	70.7
J Wheelbase	114.3	117.2	120.7	122.6	125.3
Stack	60.4	61.4	62.5	62.9	64.1
Reach	41.0	43.5	46.5	48.0	50.0

Geo

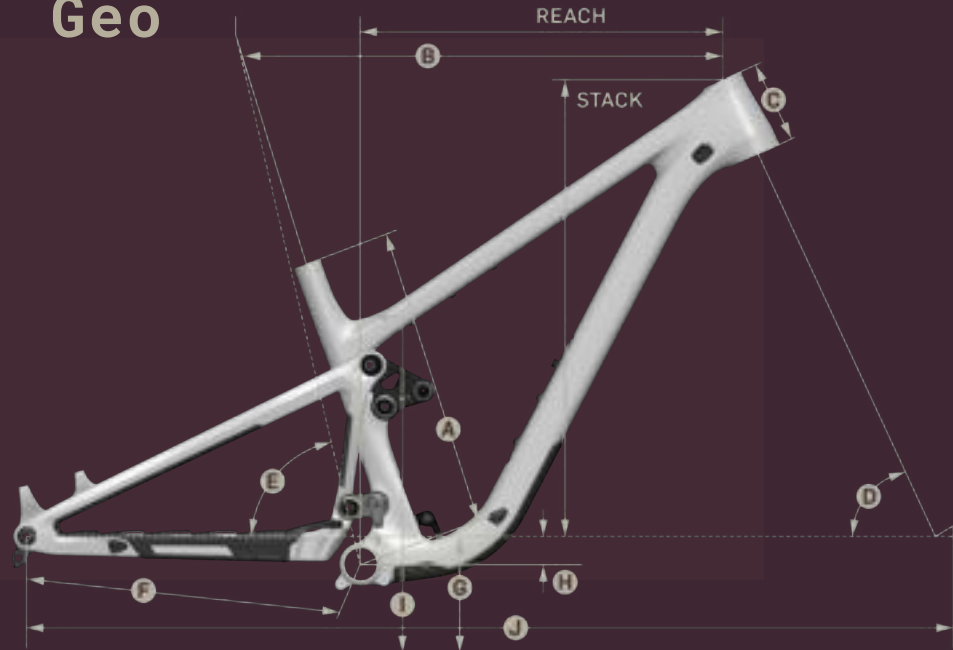

SIZES (HIGH)	XS	SM	MD	LG	XL
A Seat Tube Length (C-T)	34.3	36.8	39.4	43.2	47.0
B Top Tube Length (Eff.)	56.7	59.5	62.7	64.5	65.8
C Head Tube Length	8.5	9.5	10.7	11.2	12.5
D Head Tube Angle	66.3°	66.3°	66.3°	66.3°	66.3°
*E Seat Tube Angle (Eff.)	76.4°	76.4°	76.4°	76.4°	76.8°
F Chain Stay Length	42.9	42.9	42.9	43.0	43.2
G Bottom Bracket Height	34.4	34.4	34.5	34.5	34.5
H Bottom Bracket Drop	3.0	3.0	2.9	2.9	2.9
I Standover Height	65.7	67.8	68.2	69.6	71.2
J Wheelbase	114.2	117.1	120.6	122.5	125.2
Stack	60.1	61.0	62.1	62.5	63.7
Reach	41.5	44.0	47.0	48.5	50.5

SIZES (LOW)	XS	SM	MD	LG	XL
A Seat Tube Length (C-T)	34.3	36.8	39.4	43.2	47.0
B Top Tube Length (Eff.)	57.0	59.8	63.1	64.8	66.2
C Head Tube Length	8.5	9.5	10.7	11.2	12.5
D Head Tube Angle	65.3°	65.3°	65.3°	65.3°	65.3°
*E Seat Tube Angle (Eff.)	75.6°	75.6°	75.6°	75.6°	76.0°
F Chain Stay Length	43.1	43.1	43.1	43.3	43.5
G Bottom Bracket Height	34.0	34.0	34.0	34.0	33.9
H Bottom Bracket Drop	3.4	3.4	3.4	3.4	3.4
I Standover Height	65.9	68.0	68.3	69.6	71.2
J Wheelbase	114.8	117.7	121.2	123.1	125.7
Stack	60.9	61.8	62.9	63.4	64.6
Reach	40.5	43.0	46.0	47.5	49.5

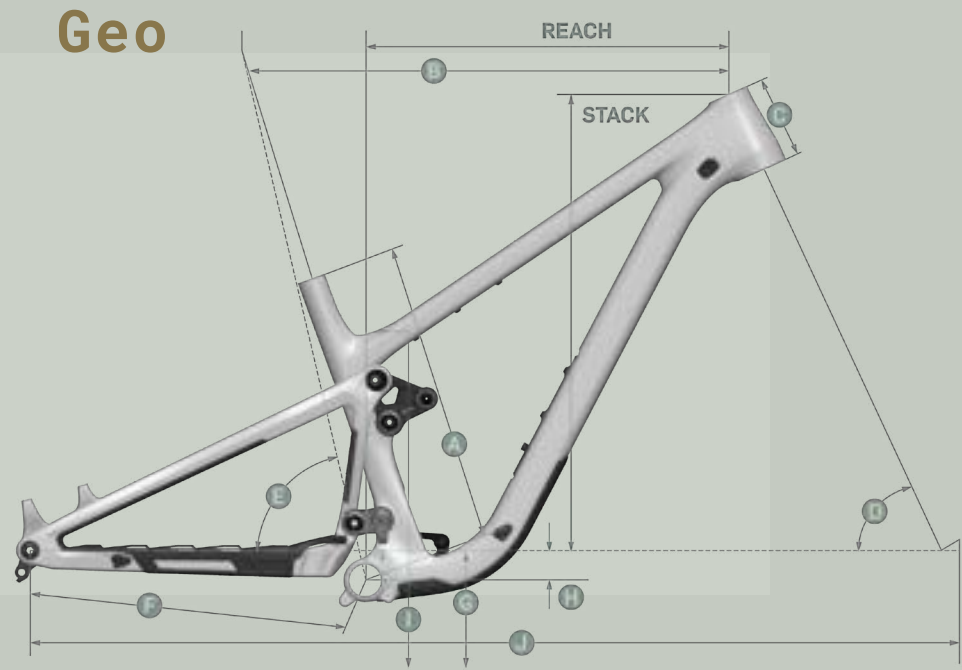

SIZES (HIGH)	XS	SM	MD	LG	XL
A Seat Tube Length (C-T)	34.3	36.8	39.4	43.2	47.0
B Top Tube Length (Eff.)	56.9	59.6	62.9	64.6	66.0
C Head Tube Length	8.5	9.5	10.7	11.2	12.5
D Head Tube Angle	65.6°	65.6°	65.6°	65.6°	65.6°
*E Seat Tube Angle (Eff.)	76.0°	76.0°	76.0°	76.0°	76.4°
F Chain Stay Length	43.0	43.0	43.0	43.1	43.3
G Bottom Bracket Height	34.6	34.6	34.6	34.6	34.6
H Bottom Bracket Drop	2.8	2.8	2.8	2.8	2.8
I Standover Height	66.2	68.3	68.7	70.1	71.6
J Wheelbase	114.7	117.6	121.1	123.0	125.6
Stack	60.5	61.4	62.5	63.0	64.2
Reach	41.0	43.5	46.5	48.0	50.0



Versatile, Dialed-In Build Options

Three no compromise build levels allow all riders to select exactly the spec to complement personal riding style. Pro and Team builds feature Fox Factory suspension while Ride builds feature Fox Performance suspension.

Upgrade options to FOX Live Valve Neo further enhances the versatility and options of the Trailcat SL and Trailcat LT.

Versatile, Dialed-In Build Options

Table Of Contents



REAR SHOCK	Fox Performance Float
FORK	Fox Performance 34 29", GRIP - 140mm
HEADSET	Pivot Precision Sealed Cartridge
REAR DERAILLEUR	Shimano XT M8100 SGS 12-Speed
SHIFTER	Shimano SLX M7100 ISPEC EV 12-Speed
CASSETTE	Shimano SLX M7100 10-51t
CHAIN	Shimano CN-M7100 12-Speed
CRANK SET	Race Face Ride 32t - 170mm(XS-MD), 175mm(LG-XL)
BRAKES	Shimano SLX M7120 4-piston
ROTORs	F - Shimano SLX 6-bolt - 180mm R - Shimano SLX 6-bolt - 180mm
HANDLEBAR	Phoenix Race Low Rise Aluminum - 780mm (XS-LG), 800mm(XL)
GRIPS	Phoenix Factory Lock-On
STEM	Phoenix Team Enduro/Trail - 35mm(XS), 45mm(SM), 55mm(MD-XL)
SEATPOST	SDG Tellis 105-125mm (XS), SDG Tellis 130-150mm (SM), SDG Tellis 150-170mm (MD), E13 Vario 180mm-210mm (LG-XL)
SADDLE	Phoenix WTB Volt Race (Medium Width)
WHEELS	DT Swiss M1900 w/ DT Swiss 370 hub, 30mm - 29" F - 15x110 / R - 12x157
WHEELS UPGRADE	N/A
TIRES	F - Maxxis Minion DHRII 29" x 2.4" WT, TR, 3C, EXO+, MAXXTERRA R - Maxxis Dissector 29" x 2.4" WT, TR, 3C, EXO, MAXXTERRA
SIZES	XS SM MD LG XL
MSRP	\$ 5,999

S

L

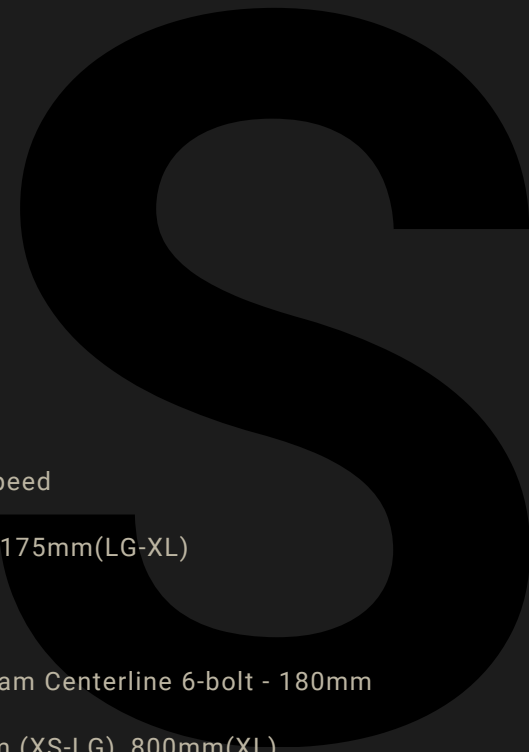

REAR SHOCK	Fox Performance Float
FORK	Fox Performance 34 29", GRIP - 140mm
HEADSET	Pivot Precision Sealed Cartridge
REAR DERAILLEUR	Sram GX Eagle Transmission 12-Speed
SHIFTER	Sram AXS Pod Controller
CASSETTE	Sram GX 1275 Eagle Transmission 10-52t
CHAIN	Sram GX Eagle Transmission Flattop 12-Speed
CRANK SET	Sram GX Eagle DUB 32t - 170mm(XS-MD), 175mm(LG-XL)
BRAKES	Sram DB8 4-piston
ROTORs	F - Sram Centerline 6-bolt - 180mm R - Sram Centerline 6-bolt - 180mm
HANDLEBAR	Phoenix Race Low Rise Aluminum - 780mm (XS-LG), 800mm(XL)
GRIPS	Phoenix Factory Lock-On
STEM	Phoenix Team Enduro/Trail - 35mm(XS), 45mm(SM), 55mm(MD-XL)
SEATPOST	SDG Tellis 105-125mm (XS), SDG Tellis 130-150mm (SM), SDG Tellis 150-170mm (MD), E13 Vario 180mm-210mm (LG-XL)
SADDLE	Phoenix WTB Volt Race (Medium Width)
WHEELS	DT Swiss M1900 w/ DT Swiss 370 hub, 30mm - 29" F - 15x110 / R - 12x157
WHEELS UPGRADE	N/A
TIRES	F - Maxxis Minion DHRII 29" x 2.4" WT, TR, 3C, EXO+, MAXXTERRA R - Maxxis Dissector 29" x 2.4" WT, TR, 3C, EXO, MAXXTERRA
SIZES	XS SM MD LG XL
MSRP	\$ 6,799

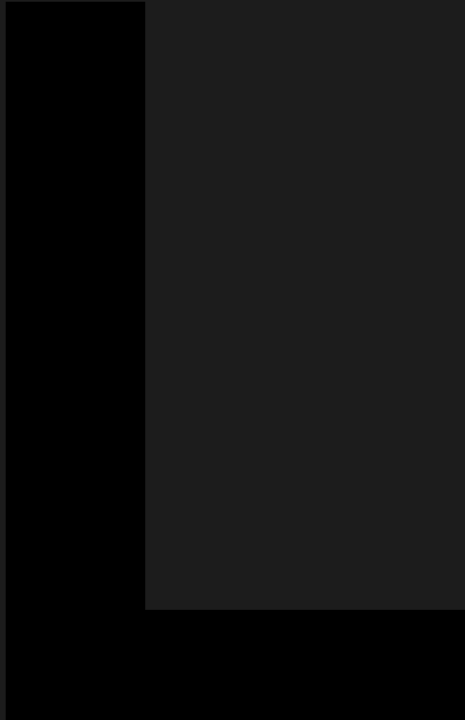

REAR SHOCK	Fox Factory Float
FORK	Fox Factory 34 29", GRIPX2 - 140mm
HEADSET	Pivot Precision Sealed Cartridge
REAR DERAILLEUR	Shimano XTR M9100 SGS 12-Speed
SHIFTER	Shimano XT M8100 ISPEC EV 12-Speed
CASSETTE	Shimano XT M8100 10-51t
CHAIN	Shimano CN-M8100 12-Speed
CRANK SET	Race Face Æffect R 32t - 170mm(XS-MD), 175mm(LG-XL)
BRAKES	Shimano XT M8120 4-piston
ROTORs	F - Shimano XT CenterLock - 180mm R - Shimano XT CenterLock - 180mm
HANDLEBAR	Phoenix Team Low Rise Carbon - 780mm (XS-LG), 800mm (XL)
GRIPS	Phoenix Factory Lock-On
STEM	Phoenix Team Enduro/Trail - 35mm(XS), 45mm(SM), 55mm(MD-XL)
SEATPOST	Fox Transfer Factory Series 95-120mm (XS), 125-150mm (SM), 155mm -180mm (MD), 185-210mm (LG-XL)
SADDLE	Phoenix WTB Volt Pro (Medium Width)
WHEELS	DT Swiss XM1700 w/ DT Swiss 350 hub & 36t Star Ratchet 30mm - 29" F - 15x110 / R - 12x157
WHEELS UPGRADE	Reynolds Blacklabel 309/289 XC w/ Industry Nine Hydra hub 30mm F 28mm R - 29" F - 15x110 / R - 12x157
TIRES	F - Maxxis Minion DHRII 29" x 2.4" WT, TR, 3C, EXO+, MAXXTERRA R - Maxxis Dissector 29" x 2.4" WT, TR, 3C, EXO, MAXXTERRA
SIZES	XS SM MD LG XL
MSRP	\$ 7,499 - \$ 8,699

REAR SHOCK	Fox Factory Float X Neo Live
FORK	Fox Factory 34 29", GRIPX2 - 140mm
HEADSET	Pivot Precision Sealed Cartridge
REAR DERAILLEUR	Shimano XTR M9100 SGS 12-Speed
SHIFTER	Shimano XT M8100 ISPEC EV 12-Speed
CASSETTE	Shimano XT M8100 10-51t
CHAIN	Shimano CN-M8100 12-Speed
CRANK SET	Race Face Æffect R 32t - 170mm(XS-MD), 175mm(LG-XL)
BRAKES	Shimano XT M8120 4-piston
ROTORs	F - Shimano XT CenterLock - 180mm R - Shimano XT CenterLock - 180mm
HANDLEBAR	Phoenix Team Low Rise Carbon - 780mm (XS-LG), 800mm (XL)
GRIPS	Phoenix Factory Lock-On
STEM	Phoenix Team Enduro/Trail - 35mm(XS), 45mm(SM), 55mm(MD-XL)
SEATPOST	Fox Transfer Neo Factory Series 125mm (XS), 150mm (SM), 175mm (MD), 200mm (LG-XL)
SADDLE	Phoenix WTB Volt Pro (Medium Width)
WHEELS	DT Swiss XM1700 w/ DT Swiss 350 hub & 36t Star Ratchet 30mm - 29" F - 15x110 / R - 12x157
WHEELS UPGRADE	Reynolds Blacklabel 309/289 XC w/ Industry Nine Hydra hub 30mm F 28mm R - 29" F - 15x110 / R - 12x157
TIRES	F - Maxxis Minion DHR II 29" x 2.4" WT, TR, 3C, EXO+, MAXXTERRA R - Maxxis Dissector 29" x 2.4" WT, TR, 3C, EXO, MAXXTERRA
SIZES	XS SM MD LG XL
MSRP	\$ 7,499 - \$ 10,699

REAR SHOCK	Fox Factory Float
FORK	Fox Factory 34 29", GRIPX2 - 140mm
HEADSET	Pivot Precision Sealed Cartridge
REAR DERAILLEUR	Sram X0 Eagle Transmission 12-Speed
SHIFTER	Sram AXS Pod Controller
CASSETTE	Sram X0 1295 Eagle Transmission 10-52t
CHAIN	Sram X0 Eagle Transmission Flattop 12-Speed
CRANK SET	Sram X0 Eagle DUB 32t - 170mm(XS-MD), 175mm(LG-XL)
BRAKES	Sram Maven Silver 4-piston
ROTORs	F - Sram HS2 Centerlock - 180mm R - Sram HS2 Centerlock - 180mm
HANDLEBAR	Phoenix Team Low Rise Carbon - 780mm (XS-LG), 800mm (XL)
GRIPS	Phoenix Factory Lock-On
STEM	Phoenix Team Enduro/Trail - 35mm(XS), 45mm(SM), 55mm(MD-XL)
SEATPOST	Fox Transfer Factory Series 95-120mm (XS), 125-150mm (SM), 155mm -180mm (MD), 185-210mm (LG-XL)
SADDLE	Phoenix WTB Volt Pro (Medium Width)
WHEELS	DT Swiss XM1700 w/ DT Swiss 350 hub & 36t Star Ratchet 30mm - 29" F - 15x110 / R - 12x157
WHEELS UPGRADE	Reynolds Blacklabel 309/289 XC w/ Industry Nine Hydra hub 30mm F 28mm R - 29" F - 15x110 / R - 12x157
TIRES	F - Maxxis Minion DHRII 29" x 2.4" WT, TR, 3C, EXO+, MAXXTERRA R - Maxxis Dissector 29" x 2.4" WT, TR, 3C, EXO, MAXXTERRA
SIZES	XS SM MD LG XL
MSRP	\$ 8,499 - \$ 9,699

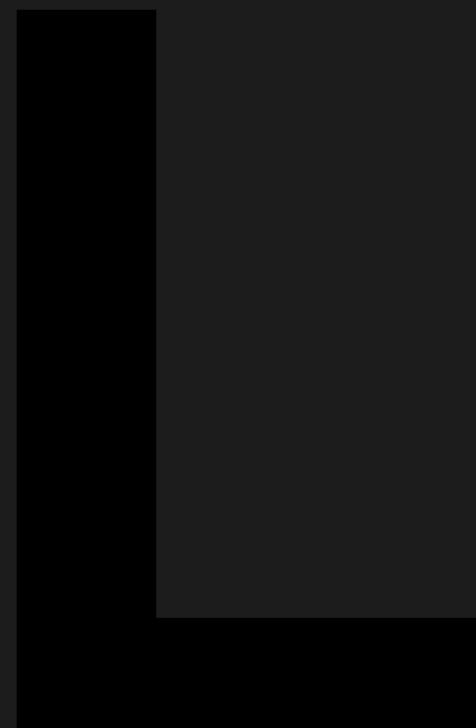
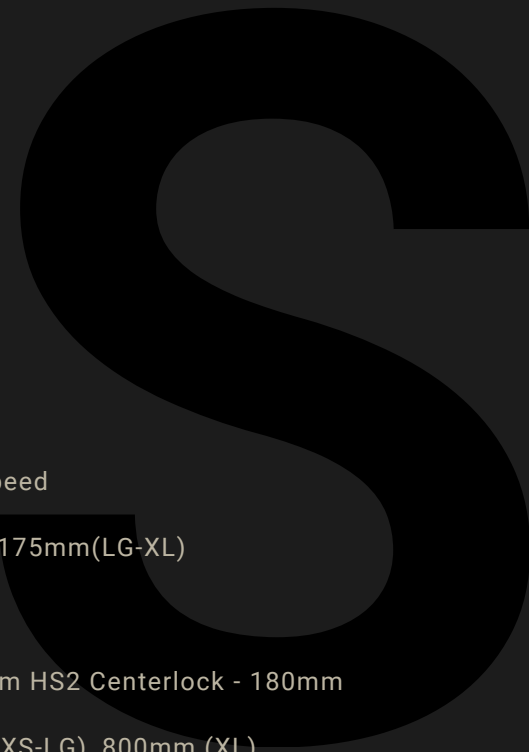

REAR SHOCK	Fox Factory Float X Neo Live
FORK	Fox Factory 34 29", GRIPX2 - 140mm
HEADSET	Pivot Precision Sealed Cartridge
REAR DERAILLEUR	Sram X0 Eagle Transmission 12-Speed
SHIFTER	Sram AXS Pod Controller
CASSETTE	Sram X0 1295 Eagle Transmission 10-52t
CHAIN	Sram X0 Eagle Transmission Flattop 12-Speed
CRANK SET	Sram X0 Eagle DUB 32t - 170mm(XS-MD), 175mm(LG-XL)
BRAKES	Sram Maven Silver 4-piston
ROTORs	F - Sram HS2 Centerlock - 180mm R - Sram HS2 Centerlock - 180mm
HANDLEBAR	Phoenix Team Low Rise Carbon - 780mm (XS-LG), 800mm (XL)
GRIPS	Phoenix Factory Lock-On
STEM	Phoenix Team Enduro/Trail - 35mm(XS), 45mm(SM), 55mm(MD-XL)
SEATPOST	Fox Transfer Neo Factory Series 125mm (XS), 150mm (SM), 175mm (MD), 200mm (LG-XL)
SADDLE	Phoenix WTB Volt Pro (Medium Width)
WHEELS	DT Swiss XM1700 w/ DT Swiss 350 hub & 36t Star Ratchet 30mm - 29" F - 15x110 / R - 12x157
WHEELS UPGRADE	Reynolds Blacklabel 309/289 XC w/ Industry Nine Hydra hub 30mm F 28mm R - 29" F - 15x110 / R - 12x157
TIRES	F - Maxxis Minion DHRII 29" x 2.4" WT, TR, 3C, EXO+, MAXXTERRA R - Maxxis Dissector 29" x 2.4" WT, TR, 3C, EXO, MAXXTERRA
SIZES	XS SM MD LG XL
MSRP	\$ 10,499 - \$ 11,699

REAR SHOCK	Fox Factory Float
FORK	Fox Factory 34 29", GRIPX2 - 140mm
HEADSET	Pivot Precision Sealed Cartridge
REAR DERAILLEUR	Shimano XTR M9100 SGS 12-Speed
SHIFTER	Shimano XTR M9100 ISPEC EV 12-Speed
CASSETTE	Shimano XTR M9100 10-51t
CHAIN	Shimano CN-M9100 12-Speed
CRANK SET	Race Face Next R 32t - 170mm(XS-MD), 175mm(LG-XL)
BRAKES	Shimano XTR M9120 4-piston
ROTORs	F - Shimano XTR CenterLock - 180mm R - Shimano XTR CenterLock - 180mm
HANDLEBAR	Phoenix Team Low Rise Carbon - 780mm (XS-LG), 800mm (XL)
GRIPS	Phoenix Factory Lock-On
STEM	Phoenix Team Enduro/Trail - 35mm(XS), 45mm(SM), 55mm(MD-XL)
SEATPOST	Fox Transfer Factory Series 125mm (XS), 150mm (SM), 155mm -180mm (MD), 210mm (LG-XL)
SADDLE	Phoenix WTB Volt Team (Medium Width)
WHEELS	Reynolds Blacklabel 309/289 XC w/ Industry Nine Hydra hub 30mm F 28mm R - 29" F - 15x110 / R - 12x157
WHEELS UPGRADE	N/A
TIRES	F - Maxxis Minion DHRII 29" x 2.4" WT, TR, 3C, EXO+, MAXXTERRA R - Maxxis Dissector 29" x 2.4" WT, TR, 3C, EXO, MAXXTERRA
SIZES	XS SM MD LG XL
MSRP	\$ 9,299

REAR SHOCK	Fox Factory Float X Neo Live
FORK	Fox Factory 34 29", GRIPX2 - 140mm
HEADSET	Pivot Precision Sealed Cartridge
REAR DERAILLEUR	Shimano XTR M9100 SGS 12-Speed
SHIFTER	Shimano XTR M9100 ISPEC EV 12-Speed
CASSETTE	Shimano XTR M9100 10-51t
CHAIN	Shimano CN-M9100 12-Speed
CRANK SET	Race Face Next R 32t - 170mm(XS-MD), 175mm(LG-XL)
BRAKES	Shimano XTR M9120 4-piston
ROTORs	F - Shimano XTR CenterLock - 180mm R - Shimano XTR CenterLock - 180mm
HANDLEBAR	Phoenix Team Low Rise Carbon - 780mm (XS-LG), 800mm (XL)
GRIPS	Phoenix Factory Lock-On
STEM	Phoenix Team Enduro/Trail - 35mm(XS), 45mm(SM), 55mm(MD-XL)
SEATPOST	Fox Transfer Neo Factory Series 125mm (XS), 150mm (SM), 175mm (MD), 200mm (LG-XL)
SADDLE	Phoenix WTB Volt Team (Medium Width)
WHEELS	Reynolds Blacklabel 309/289 XC w/ Industry Nine Hydra hub 30mm F 28mm R - 29" F - 15x110 / R - 12x157
WHEELS UPGRADE	N/A
TIRES	F - Maxxis Minion DHRII 29" x 2.4" WT, TR, 3C, EXO+, MAXXTERRA R - Maxxis Dissector 29" x 2.4" WT, TR, 3C, EXO, MAXXTERRA
SIZES	XS SM MD LG XL
MSRP	\$ 11,299

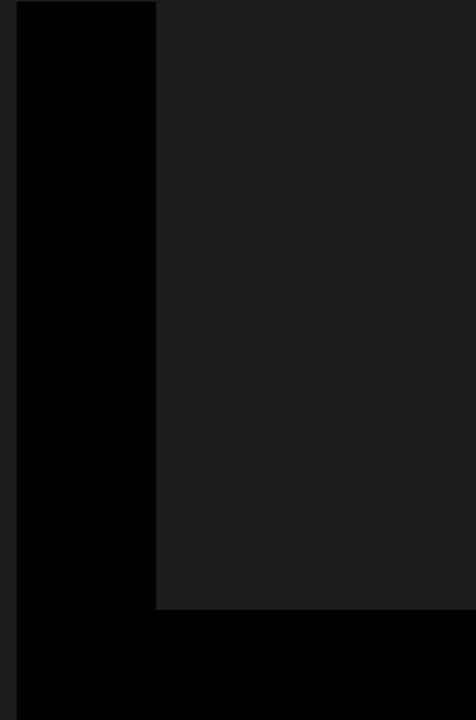
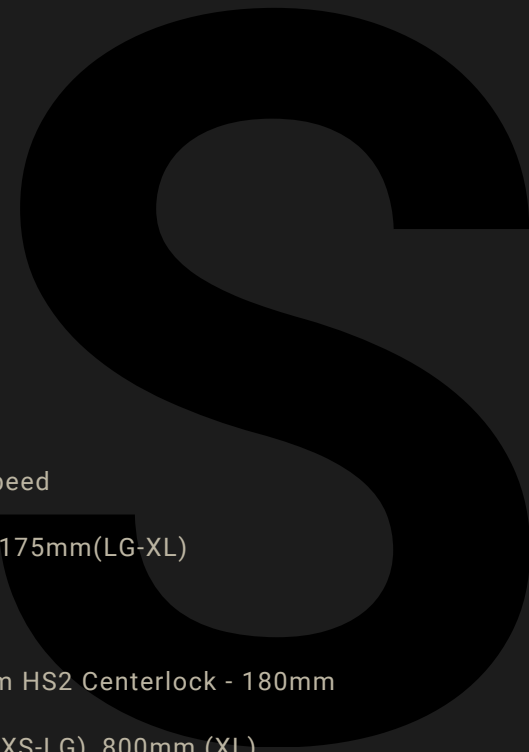

REAR SHOCK	Fox Factory Float
FORK	Fox Factory 34 29", GRIPX2 - 140mm
HEADSET	Pivot Precision Sealed Cartridge
REAR DERAILLEUR	Sram XX Eagle Transmission 12-Speed
SHIFTER	Sram AXS Pod Ultimate Controller
CASSETTE	Sram XX 1297 Eagle Transmission 10-52t
CHAIN	Sram XX Eagle Transmission Flattop 12-Speed
CRANK SET	Sram XX Eagle DUB 32t - 170mm(XS-MD), 175mm(LG-XL)
BRAKES	Sram Maven Ultimate 4-piston
ROTORs	F - Sram HS2 Centerlock - 180mm R - Sram HS2 Centerlock - 180mm
HANDLEBAR	Phoenix Team Low Rise Carbon - 780mm (XS-LG), 800mm (XL)
GRIPS	Phoenix Factory Lock-On
STEM	Phoenix Team Enduro/Trail - 35mm(XS), 45mm(SM), 55mm(MD-XL)
SEATPOST	Rock Shox Reverb AXS 100mm (XS), 125mm (SM), 150mm (MD-LG) 170mm (XL)
SADDLE	Phoenix WTB Volt Team (Medium Width)
WHEELS	Reynolds Blacklabel 309/289 XC w/ Industry Nine Hydra hub 30mm F 28mm R - 29" F - 15x110 / R - 12x157
WHEELS UPGRADE	N/A
TIRES	F - Maxxis Minion DHRII 29" x 2.4" WT, TR, 3C, EXO+, MAXXTERRA R - Maxxis Dissector 29" x 2.4" WT, TR, 3C, EXO, MAXXTERRA
SIZES	XS SM MD LG XL
MSRP	\$ 11,099

REAR SHOCK	Fox Factory Float X Neo Live
FORK	Fox Factory 34 29", GRIPX2 - 140mm
HEADSET	Pivot Precision Sealed Cartridge
REAR DERAILLEUR	Sram XX Eagle Transmission 12-Speed
SHIFTER	Sram AXS Pod Ultimate Controller
CASSETTE	Sram XX 1297 Eagle Transmission 10-52t
CHAIN	Sram XX Eagle Transmission Flatop 12-Speed
CRANK SET	Sram XX Eagle DUB 32t - 170mm(XS-MD), 175mm(LG-XL)
BRAKES	Sram Maven Ultimate 4-piston
ROTORs	F - Sram HS2 Centerlock - 180mm R - Sram HS2 Centerlock - 180mm
HANDLEBAR	Phoenix Team Low Rise Carbon - 780mm (XS-LG), 800mm (XL)
GRIPS	Phoenix Factory Lock-On
STEM	Phoenix Team Enduro/Trail - 35mm(XS), 45mm(SM), 55mm(MD-XL)
SEATPOST	Rock Shox Reverb AXS 100mm (XS), 125mm (SM), 150mm (MD-LG) 170mm (XL)
SADDLE	Phoenix WTB Volt Team (Medium Width)
WHEELS	Reynolds Blacklabel 309/289 XC w/ Industry Nine Hydra hub 30mm F 28mm R - 29" F - 15x110 / R - 12x157
WHEELS UPGRADE	N/A
TIRES	F - Maxxis Minion DHRII 29" x 2.4" WT, TR, 3C, EXO+, MAXXTERRA R - Maxxis Dissector 29" x 2.4" WT, TR, 3C, EXO, MAXXTERRA
SIZES	XS SM MD LG XL
MSRP	\$ 13,099

REAR SHOCK	Fox Performance Float X
FORK	Fox Performance 36 29", GRIP - 150mm
HEADSET	Pivot Precision Sealed Cartridge
REAR DERAILLEUR	Shimano XT M8100 SGS 12-Speed
SHIFTER	Shimano SLX M7100 ISPEC EV 12-Speed
CASSETTE	Shimano SLX M7100 10-51t
CHAIN	Shimano CN-M7100 12-Speed
CRANK SET	Race Face Ride 32t - 170mm(XS-SM), 175mm(MD-XL)
BRAKES	Shimano SLX M7120 4-piston
ROTORs	F - Shimano SLX 6-bolt - 203mm R - Shimano SLX 6-bolt - 180mm
HANDLEBAR	Phoenix Race Low Rise Aluminum - 780mm (XS-LG), 800mm(XL)
GRIPS	Phoenix Factory Lock-On
STEM	Phoenix Team Enduro/Trail - 35mm(XS), 45mm(SM), 55mm(MD-XL)
SEATPOST	SDG Tellis 105-125mm (XS), SDG Tellis 130-150mm (SM), SDG Tellis 150-170mm (MD), E13 Vario 180mm-210mm (LG-XL)
SADDLE	Phoenix WTB Volt Race (Medium Width)
WHEELS	DT Swiss M1900 w/ DT Swiss 370 hub, 30mm - 29" F - 15x110 / R - 12x157
WHEELS UPGRADE	N/A
TIRES	F - Maxxis Minion DHRII 29" x 2.4" WT, TR, 3C, EXO+, MAXXTERRA R - Maxxis Dissector 29" x 2.4" WT, TR, 3C, EXO, MAXXTERRA
SIZES	XS SM MD LG XL
MSRP	\$ 6,199

REAR SHOCK	Fox Performance Float X
FORK	Fox Performance 36 29", GRIP - 150mm
HEADSET	Pivot Precision Sealed Cartridge
REAR DERAILLEUR	Sram GX Eagle Transmission 12-Speed
SHIFTER	Sram AXS Pod Controller
CASSETTE	Sram GX 1275 Eagle Transmission 10-52t
CHAIN	Sram GX Eagle Transmission Flatop 12-Speed
CRANK SET	Sram GX Eagle DUB 32t - 165mm(XS), 170mm(SM-XL)
BRAKES	Sram DB8 4-piston
ROTORs	F - Sram Centerline 6-bolt - 180mm R - Sram Centerline 6-bolt - 180mm
HANDLEBAR	Phoenix Race Low Rise Aluminum - 780mm (XS-LG), 800mm(XL)
GRIPS	Phoenix Factory Lock-On
STEM	Phoenix Team Enduro/Trail - 35mm(XS), 45mm(SM), 55mm(MD-XL)
SEATPOST	SDG Tellis 105-125mm (XS), SDG Tellis 130-150mm (SM), SDG Tellis 150-170mm (MD), E13 Vario 180mm-210mm (LG-XL)
SADDLE	Phoenix WTB Volt Race (Medium Width)
WHEELS	DT Swiss M1900 w/ DT Swiss 370 hub, 30mm - 29" F - 15x110 / R - 12x157
WHEELS UPGRADE	N/A
TIRES	F - Maxxis Minion DHRII 29" x 2.4" WT, TR, 3C, EXO+, MAXXTERRA R - Maxxis Dissector 29" x 2.4" WT, TR, 3C, EXO, MAXXTERRA
SIZES	XS SM MD LG XL
MSRP	\$ 6,999

REAR SHOCK	Fox Factory Float X
FORK	Fox Factory 36 29", GRIPX2 - 150mm
HEADSET	Pivot Precision Sealed Cartridge
REAR DERAILLEUR	Shimano XTR M9100 SGS 12-Speed
SHIFTER	Shimano XT M8100 ISPEC EV 12-Speed
CASSETTE	Shimano XT M8100 10-51t
CHAIN	Shimano CN-M8100 12-Speed
CRANK SET	Race Face Æffect R 32t - 170mm(XS-MD), 175mm(LG-XL)
BRAKES	Shimano XT M8120 4-piston
ROTORs	F - Shimano XT CenterLock - 203mm R - Shimano XT CenterLock - 180mm
HANDLEBAR	Phoenix Team Low Rise Carbon - 780mm (XS-LG), 800mm (XL)
GRIPS	Phoenix Factory Lock-On
STEM	Phoenix Team Enduro/Trail - 35mm(XS), 45mm(SM), 55mm(MD-XL)
SEATPOST	Fox Transfer Factory Series 125mm (XS), 150mm (SM), 155mm -180mm (MD), 210mm (LG-XL)
SADDLE	Phoenix WTB Volt Pro (Medium Width)
WHEELS	DT Swiss XM1700 w/ DT Swiss 350 hub & 36t Star Ratchet 30mm - 29" F - 15x110 / R - 12x157
WHEELS UPGRADE	Reynolds Blacklabel 329 Trail Pro w/ Industry Nine Hydra hub 30mm F 28mm R - 29" F - 15x110 / R - 12x157
TIRES	F - Maxxis Minion DHRII 29" x 2.4" WT, TR, 3C, EXO+, MAXXTERRA R - Maxxis Dissector 29" x 2.4" WT, TR, 3C, EXO, MAXXTERRA
SIZES	XS SM MD LG XL
MSRP	\$ 7,699 - \$ 8,899

REAR SHOCK	Fox Factory Float X Neo Live
FORK	Fox Factory 36 29", GRIPX2 - 150mm
HEADSET	Pivot Precision Sealed Cartridge
REAR DERAILLEUR	Shimano XTR M9100 SGS 12-Speed
SHIFTER	Shimano XT M8100 ISPEC EV 12-Speed
CASSETTE	Shimano XT M8100 10-51t
CHAIN	Shimano CN-M8100 12-Speed
CRANK SET	Race Face Æffect R 32t - 170mm(XS-MD), 175mm(LG-XL)
BRAKES	Shimano XT M8120 4-piston
ROTORs	F - Shimano XT CenterLock - 203mm R - Shimano XT CenterLock - 180mm
HANDLEBAR	Phoenix Team Low Rise Carbon - 780mm (XS-LG), 800mm (XL)
GRIPS	Phoenix Factory Lock-On
STEM	Phoenix Team Enduro/Trail - 35mm(XS), 45mm(SM), 55mm(MD-XL)
SEATPOST	Fox Transfer Neo Factory Series 125mm (XS), 150mm (SM), 175mm (MD), 200mm (LG-XL)
SADDLE	Phoenix WTB Volt Pro (Medium Width)
WHEELS	DT Swiss XM1700 w/ DT Swiss 350 hub & 36t Star Ratchet 30mm - 29" F - 15x110 / R - 12x157
WHEELS UPGRADE	Reynolds Blacklabel 329 Trail Pro w/ Industry Nine Hydra hub 30mm F 28mm R - 29" F - 15x110 / R - 12x157
TIRES	F - Maxxis Minion DHRII 29" x 2.4" WT, TR, 3C, EXO+, MAXXTERRA R - Maxxis Dissector 29" x 2.4" WT, TR, 3C, EXO, MAXXTERRA
SIZES	XS SM MD LG XL
MSRP	\$ 9,699 - \$ 10,899

REAR SHOCK	Fox Factory Float X
FORK	Fox Factory 36 29", GRIPX2 - 150mm
HEADSET	Pivot Precision Sealed Cartridge
REAR DERAILLEUR	Sram X0 Eagle Transmission 12-Speed
SHIFTER	Sram AXS Pod Controller
CASSETTE	Sram X0 1295 Eagle Transmission 10-52t
CHAIN	Sram X0 Eagle Transmission Flattop 12-Speed
CRANK SET	Sram X0 Eagle DUB 32t - 165mm(XS), 170mm(SM-XL)
BRAKES	Sram Maven Silver 4-piston
ROTORs	F - Sram HS2 Centerlock - 180mm R - Sram HS2 Centerlock - 180mm
HANDLEBAR	Phoenix Team Low Rise Carbon - 780mm (XS-LG), 800mm (XL)
GRIPS	Phoenix Factory Lock-On
STEM	Phoenix Team Enduro/Trail - 35mm(XS), 45mm(SM), 55mm(MD-XL)
SEATPOST	Fox Transfer Factory Series 95-120mm (XS), 125-150mm (SM), 155mm -180mm (MD), 185-210mm (LG-XL)
SADDLE	Phoenix WTB Volt Pro (Medium Width)
WHEELS	DT Swiss XM1700 w/ DT Swiss 350 hub & 36t Star Ratchet 30mm - 29" F - 15x110 / R - 12x157
WHEELS UPGRADE	Reynolds Blacklabel 309/289 XC w/ Industry Nine Hydra hub 30mm F 28mm R - 29" F - 15x110 / R - 12x157
TIRES	F - Maxxis Minion DHRII 29" x 2.4" WT, TR, 3C, EXO+, MAXXTERRA R - Maxxis Dissector 29" x 2.4" WT, TR, 3C, EXO, MAXXTERRA
SIZES	XS SM MD LG XL
MSRP	\$ 8,699 - \$ 9,899

REAR SHOCK	Fox Factory Float X Neo Live
FORK	Fox Factory 36 29", GRIPX2 - 150mm
HEADSET	Pivot Precision Sealed Cartridge
REAR DERAILLEUR	Sram X0 Eagle Transmission 12-Speed
SHIFTER	Sram AXS Pod Controller
CASSETTE	Sram X0 1295 Eagle Transmission 10-52t
CHAIN	Sram X0 Eagle Transmission Flattop 12-Speed
CRANK SET	Sram X0 Eagle DUB 32t - 165mm(XS), 170mm(SM-XL)
BRAKES	Sram Maven Silver 4-piston
ROTORs	F - Sram HS2 Centerlock - 180mm R - Sram HS2 Centerlock - 180mm
HANDLEBAR	Phoenix Team Low Rise Carbon - 780mm (XS-LG), 800mm (XL)
GRIPS	Phoenix Factory Lock-On
STEM	Phoenix Team Enduro/Trail - 35mm(XS), 45mm(SM), 55mm(MD-XL)
SEATPOST	Fox Transfer Neo Factory Series 125mm (XS), 150mm (SM), 175mm (MD), 200mm (LG-XL)
SADDLE	Phoenix WTB Volt Pro (Medium Width)
WHEELS	DT Swiss XM1700 w/ DT Swiss 350 hub & 36t Star Ratchet 30mm - 29" F - 15x110 / R - 12x157
WHEELS UPGRADE	Reynolds Blacklabel 309/289 XC w/ Industry Nine Hydra hub 30mm F 28mm R - 29" F - 15x110 / R - 12x157
TIRES	F - Maxxis Minion DHRII 29" x 2.4" WT, TR, 3C, EXO+, MAXXTERRA R - Maxxis Dissector 29" x 2.4" WT, TR, 3C, EXO, MAXXTERRA
SIZES	XS SM MD LG XL
MSRP	\$ 10,699 - \$ 11,899

REAR SHOCK	Fox Factory Float X
FORK	Fox Factory 36 29", GRIPX2 - 150mm
HEADSET	Pivot Precision Sealed Cartridge
REAR DERAILLEUR	Shimano XTR M9100 SGS 12-Speed
SHIFTER	Shimano XTR M9100 ISPEC EV 12-Speed
CASSETTE	Shimano XTR M9100 10-51t
CHAIN	Shimano CN-M9100 12-Speed
CRANK SET	Race Face Next R 32t - 170mm(XS-MD), 175mm(LG-XL)
BRAKES	Shimano XTR M9120 4-piston
ROTORs	F - Shimano XTR CenterLock - 203mm R - Shimano XTR CenterLock - 180mm
HANDLEBAR	Phoenix Team Low Rise Carbon - 780mm (XS-LG), 800mm (XL)
GRIPS	Phoenix Factory Lock-On
STEM	Phoenix Team Enduro/Trail - 35mm(XS), 45mm(SM), 55mm(MD-XL)
SEATPOST	Fox Transfer Factory Series 125mm (XS), 150mm (SM), 155mm -180mm (MD), 210mm (LG-XL)
SADDLE	Phoenix WTB Volt Team (Medium Width)
WHEELS	Reynolds Blacklabel 329 Trail Pro w/ Industry Nine Hydra hub 30mm F 28mm R - 29" F - 15x110 / R - 12x157
WHEELS UPGRADE	N/A
TIRES	F - Maxxis Minion DHRII 29" x 2.4" WT, TR, 3C, EXO+, MAXXTERRA R - Maxxis Dissector 29" x 2.4" WT, TR, 3C, EXO, MAXXTERRA
SIZES	XS SM MD LG XL
MSRP	\$ 9,499

REAR SHOCK	Fox Factory Float X Neo Live
FORK	Fox Factory 36 29", GRIPX2 - 150mm
HEADSET	Pivot Precision Sealed Cartridge
REAR DERAILLEUR	Shimano XTR M9100 SGS 12-Speed
SHIFTER	Shimano XTR M9100 ISPEC EV 12-Speed
CASSETTE	Shimano XTR M9100 10-51t
CHAIN	Shimano CN-M9100 12-Speed
CRANK SET	Race Face Next R 32t - 170mm(XS-MD), 175mm(LG-XL)
BRAKES	Shimano XTR M9120 4-piston
ROTORs	F - Shimano XTR CenterLock - 203mm R - Shimano XTR CenterLock - 180mm
HANDLEBAR	Phoenix Team Low Rise Carbon - 780mm (XS-LG), 800mm (XL)
GRIPS	Phoenix Factory Lock-On
STEM	Phoenix Team Enduro/Trail - 35mm(XS), 45mm(SM), 55mm(MD-XL)
SEATPOST	Fox Transfer Neo Factory Series 125mm (XS), 150mm (SM), 175mm (MD), 200mm (LG-XL)
SADDLE	Phoenix WTB Volt Team (Medium Width)
WHEELS	Reynolds Blacklabel 329 Trail Pro w/ Industry Nine Hydra hub 30mm F 28mm R - 29" F - 15x110 / R - 12x157
WHEELS UPGRADE	N/A
TIRES	F - Maxxis Minion DHRII 29" x 2.4" WT, TR, 3C, EXO+, MAXXTERRA R - Maxxis Dissector 29" x 2.4" WT, TR, 3C, EXO, MAXXTERRA
SIZES	XS SM MD LG XL
MSRP	\$ 11,499

REAR SHOCK	Fox Factory Float X
FORK	Fox Factory 36 29", GRIPX2 - 150mm
HEADSET	Pivot Precision Sealed Cartridge
REAR DERAILLEUR	Sram XX Eagle Transmission 12-Speed
SHIFTER	Sram AXS Pod Ultimate Controller
CASSETTE	Sram XX 1297 Eagle Transmission 10-52t
CHAIN	Sram XX Eagle Transmission Flatop 12-Speed
CRANK SET	Sram XX Eagle DUB 32t - 165mm(XS), 170mm(SM-XL)
BRAKES	Sram Maven Ultimate 4-piston
ROTORS	F - Sram HS2 Centerlock - 180mm R - Sram HS2 Centerlock - 180mm
HANDLEBAR	Phoenix Team Low Rise Carbon - 780mm (XS-LG), 800mm (XL)
GRIPS	Phoenix Factory Lock-On
STEM	Phoenix Team Enduro/Trail - 35mm(XS), 45mm(SM), 55mm(MD-XL)
SEATPOST	Rock Shox Reverb AXS 100mm (XS), 125mm (SM), 150mm (MD-LG) 170mm (XL)
SADDLE	Phoenix WTB Volt Team (Medium Width)
WHEELS	Reynolds Blacklabel 329 Trail Pro w/ Industry Nine Hydra hub 30mm F 28mm R - 29" F - 15x110 / R - 12x157
WHEELS UPGRADE	N/A
TIRES	F - Maxxis Minion DHRII 29" x 2.4" WT, TR, 3C, EXO+, MAXXTERRA R - Maxxis Dissector 29" x 2.4" WT, TR, 3C, EXO, MAXXTERRA
SIZES	XS SM MD LG XL
MSRP	\$ 11,299

REAR SHOCK	Fox Factory Float X Neo Live
FORK	Fox Factory 36 29", GRIPX2 - 150mm
HEADSET	Pivot Precision Sealed Cartridge
REAR DERAILLEUR	Sram XX Eagle Transmission 12-Speed
SHIFTER	Sram AXS Pod Ultimate Controller
CASSETTE	Sram XX 1297 Eagle Transmission 10-52t
CHAIN	Sram XX Eagle Transmission Flatop 12-Speed
CRANK SET	Sram XX Eagle DUB 32t - 165mm(XS), 170mm(SM-XL)
BRAKES	Sram Maven Ultimate 4-piston
ROTORs	F - Sram HS2 Centerlock - 180mm R - Sram HS2 Centerlock - 180mm
HANDLEBAR	Phoenix Team Low Rise Carbon - 780mm (XS-LG), 800mm (XL)
GRIPS	Phoenix Factory Lock-On
STEM	Phoenix Team Enduro/Trail - 35mm(XS), 45mm(SM), 55mm(MD-XL)
SEATPOST	Rock Shox Reverb AXS 100mm (XS), 125mm (SM), 150mm (MD-LG) 170mm (XL)
SADDLE	Phoenix WTB Volt Team (Medium Width)
WHEELS	Reynolds Blacklabel 329 Trail Pro w/ Industry Nine Hydra hub 30mm F 28mm R - 29" F - 15x110 / R - 12x157
WHEELS UPGRADE	N/A
TIRES	F - Maxxis Minion DHRII 29" x 2.4" WT, TR, 3C, EXO+, MAXXTERRA R - Maxxis Dissector 29" x 2.4" WT, TR, 3C, EXO, MAXXTERRA
SIZES	XS SM MD LG XL
MSRP	\$ 13,299



Pivot Premier Lifetime Warranty

Applicable to bikes sold on or after January 1, 2024

Bearing & frame coverage

Bike must be registered within 30 days of purchase, or April 1st, 2025
(whichever comes later) to apply

pivotcycles.com

6720 S. Clementine Court Tempe, AZ 85283

